

NOTES: REFER TO DETAIL 14/- & 15/- FOR TYPICAL NOTES, ITEMS, & DIMENSIONS NOT SHOWN.

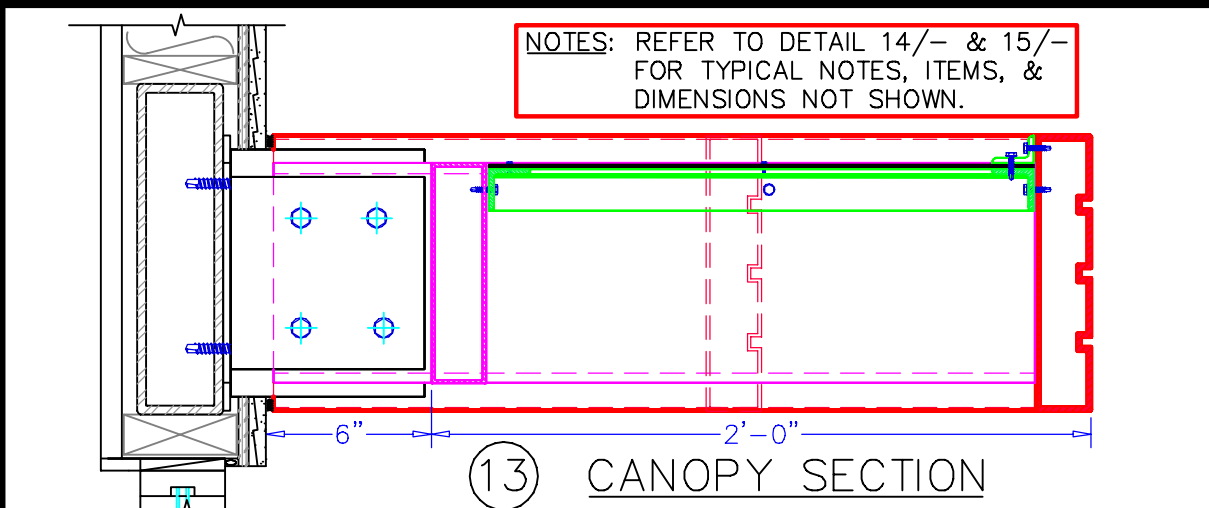

13 CANOPY SECTION

NOTES: REFER TO DETAIL 12/- FOR TYPICAL NOTES, ITEMS, AND DIMENSIONS NOT SHOWN.

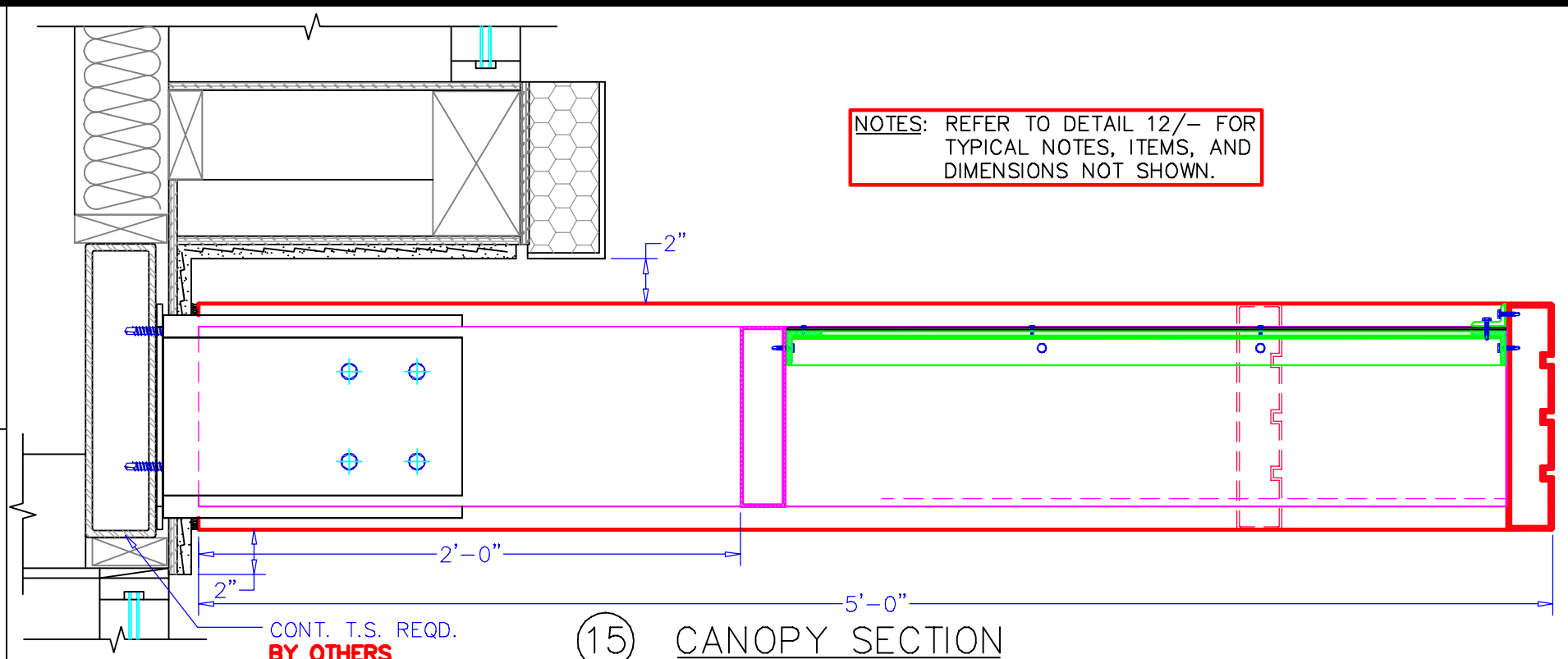

15 CANOPY SECTION

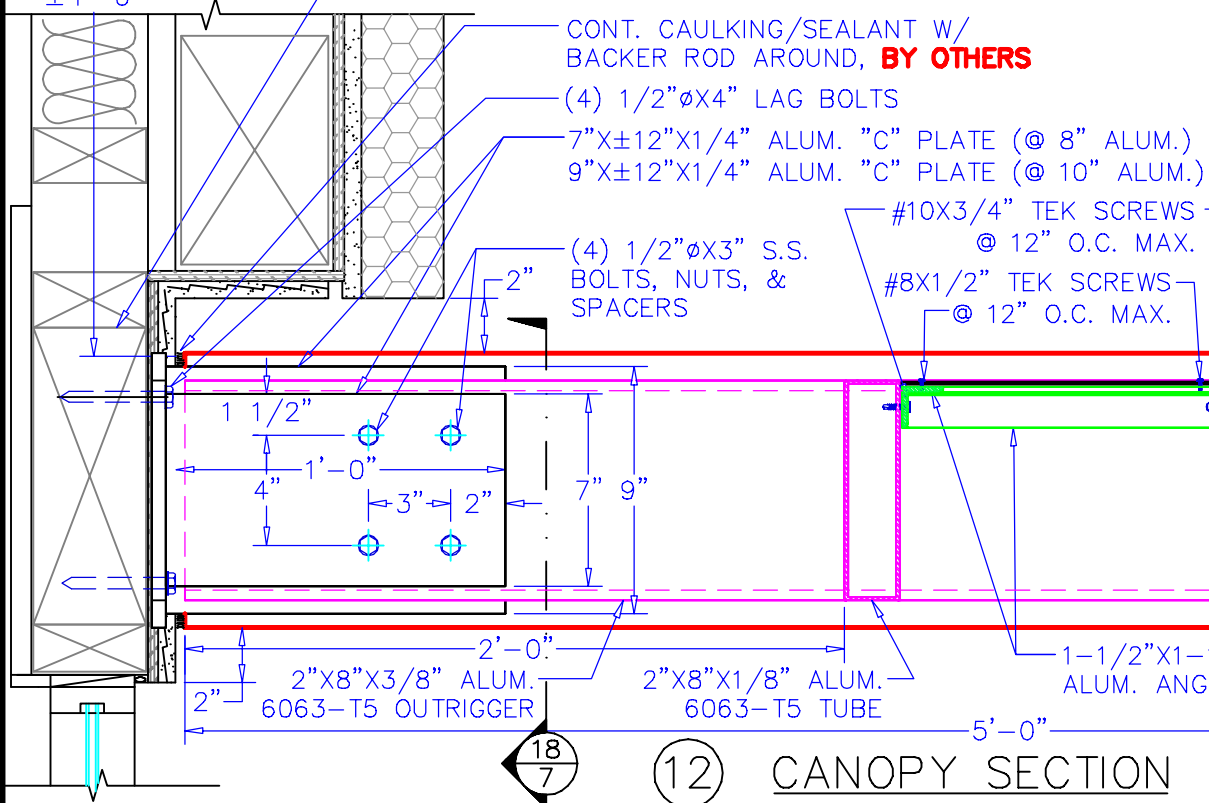
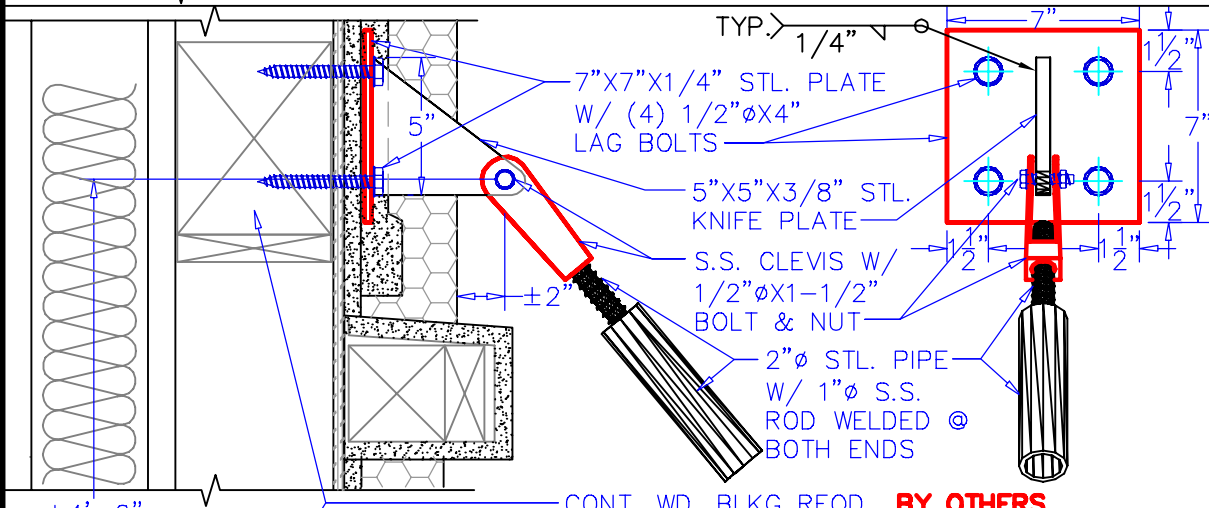

12 CANOPY SECTION

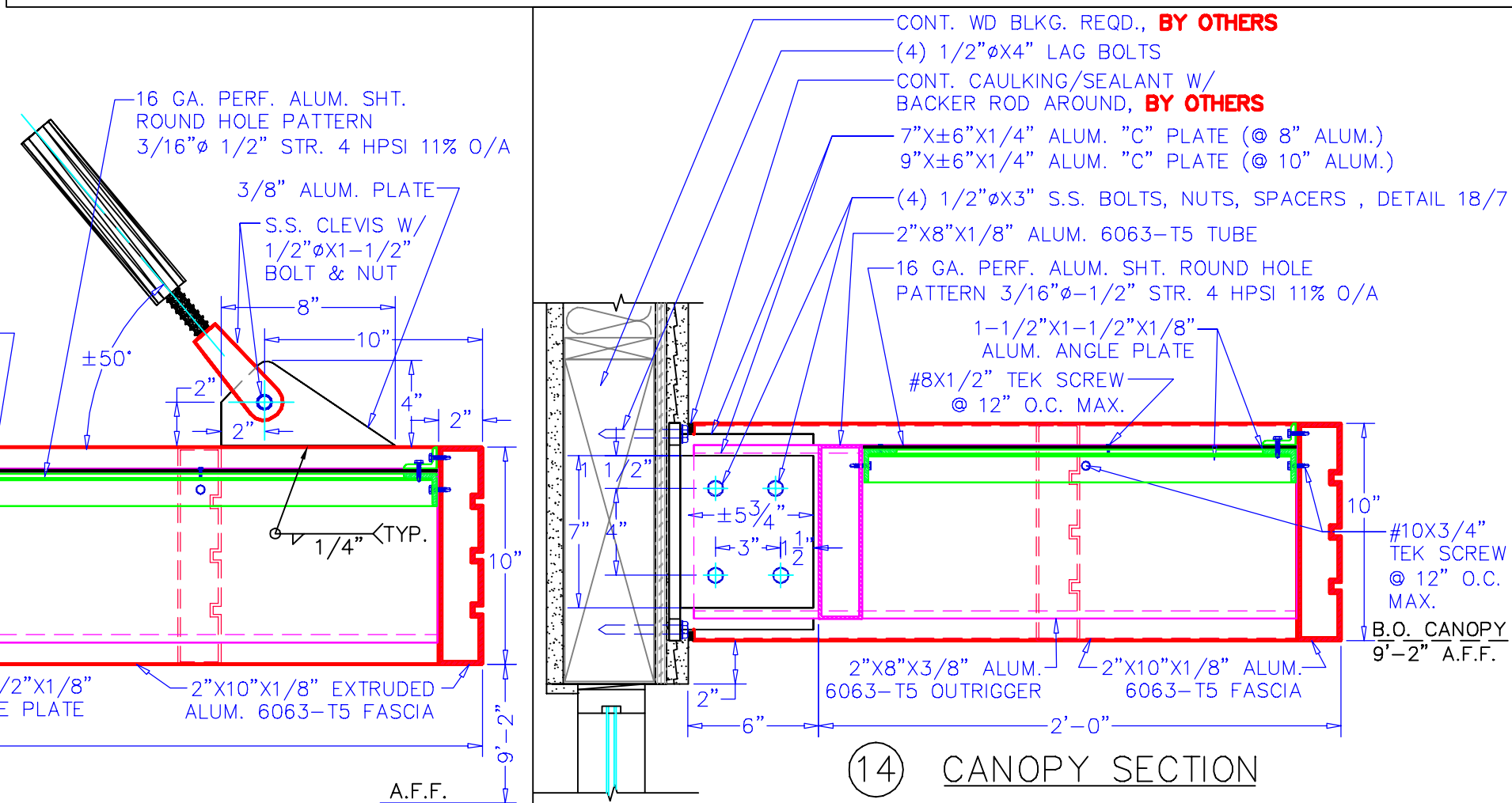

14 CANOPY SECTION

B & C AWNING, INC.  
3082 EAST MIRALOMA AVE.  
ANAHEIM, CA 92806  
TEL: (714) 632-3303  
FAX: (714)632-5632

JOB NAME: LADERA TERRACE SHOPS  
26121 1101 CORPORATE WAY  
LADERA RANCH, CA  
CONSTRUCTOR: GRANT GENERAL-CONTRACTOR

DATE: -/-/-  
SHEET NO.: -/-

THESE SHOP DRAWINGS ARE PRESENTED IN ORDER TO MORE PERFECTLY AGREE, THEY DEFINE IN DETAIL B & C AWNINGS SCOPE OF WORK, THEY BECOME THE FINAL DEFINITIVE AGREEMENT, COMPLETE INVENTORY OF WHAT BUYER/AGENT/CONTRACTOR AGREES TO BUY, SUPERSEDE ALL PLANS, SPECIFICATIONS PRIOR TO APPROVAL DATE. IN APPROVING/ STAMPING THESE DRAWINGS AGENT/BUYER AGREES TO ABOVE STATEMENTS ALSO AGREES CLAIMS AGAINST B & C AWNINGS INC. THEIR HEIRS AND ASSIGNEES TO INDEMNIFY AGENT/ CONTRACTOR, PAY ATTORNEY FEES OR DEFEND AGAINST LEGAL ACTIONS ASSOCIATED OR EMANATING THERE FROM IS LIMITED TO THE WARRANTY PERIOD PROVIDED HEREIN, FUTURE UNRESOLVED DISPUTES BEING ADDRESSED IN THE ORANGE COUNTY COURT JURISDICTION AS FORUM.